

Air injection Vacuum Blower

VTB 820.xl

Hibon Ingersoll Rand presents new state-of-the-art technology in three-lobe, positive displacement blowers. The VTB XL series air-injected, high-vacuum blowers offer a wide range of design features and incorporate energy efficiency improvements, complying with the strictest operational requirements of a variety of applications. These high-vacuum blowers are ideally suited for the rigorous demand of the vacuum truck market. Hibon is a worldwide leader in three-lobe positive displacement blower technology with thousands of units installed around the globe.

Characteristics

- Three-lobe impeller construction
- Unique air injection system
- Increased efficiency
- Clearances adjusted automatically during assembly
- Larger oil capacity
- High volume oil thrower
- High performance sealing arrangement using 4 piston rings

Benefits

- Quieter operation than two-lobe impeller construction
- Allows high vacuum including "dead end" operation without overheating
- No oil or water cooling system (100% oil free air)
- Requires less horsepower for the same performance
- Easier maintenance
- Runs cooler
- Better lubrication of bearings
- Less frequent oil changes

Configurations

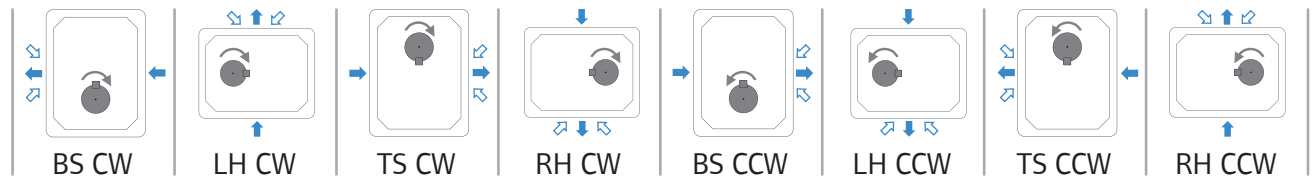

Better by design

Configuration	With feet option	without feet
BS CW	F0155701111	F015570111
LH CW	.	F015570101
TS CW	F0155701211	F015570121
RH CW	.	F015570131
BS CCW	F0155701101	F015570110
LH CCW	.	F015570100
TS CCW	F0155701201	F015570120
RH CCW	.	F015570130

- ↻ Shaft rotation
- ➡ Air flow
- ⇄ Air injection
- RH = Right hand shaft
- LH = Left hand shaft
- BS = Bottom shaft
- TS = Top shaft
- CW = Clockwise rotation
- CCW = Counter clockwise rotation

Performance chart

VOLUME DISPLACEMENT *(1661 CFM)														
Speed (RPM)	9" HG		12" HG		15" HG		18" HG		21" HG		24" HG		27" HG	
	CFM	BHP	CFM	BHP	CFM	BHP	CFM	BHP	CFM	BHP	CFM	BHP	CFM	BHP
2200	785	22	764	28	728	35	673	41	608	45	505	49	152	53
2600	948	27	955	33	894	41	843	48	778	54	683	58	290	63
2800	1030	29	1042	36	978	44	928	52	864	58	772	63	360	68
3000	1111	31	1128	39	1061	48	1014	55	949	62	861	67	429	74
3200	1193	34	1215	42	1144	51	1099	59	1035	67	950	72	498	79
3400	1275	36	1302	45	1227	55	1184	63	1120	71	1039	77	567	84
3600	1356	39	1389	49	1310	58	1269	67	1205	76	1128	83	637	90
3800	1438	42	1476	52	1393	62	1354	70	1291	80	1217	87	-	-

* Volume displacement at maximum speed.

VTB 820.XL Dimensions

BS CCW Configuration

VERTICAL GEARS

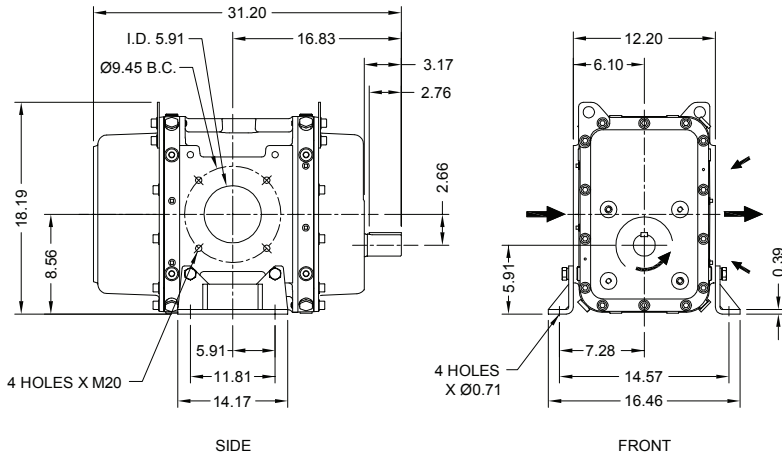

SHAFT DETAILS

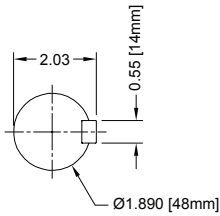

DISCHARGE FLANGE

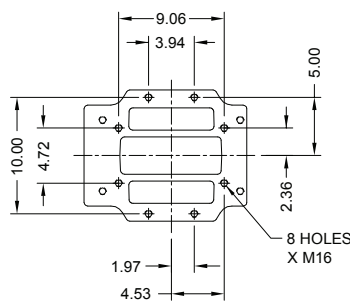

- NOTES:
1. ENGLISH UNITS (INCH) UNLESS OTHERWISE NOTED.
 2. WEIGHT: **562** lbs.
 3. C.W. SHAFT ROTATION ALSO AVAILABLE ON REQUEST.
 4. DO NOT USE FOR CONSTRUCTION.
 5. Other configurations also available on request

LH CCW Configuration

HORIZONTAL GEARS

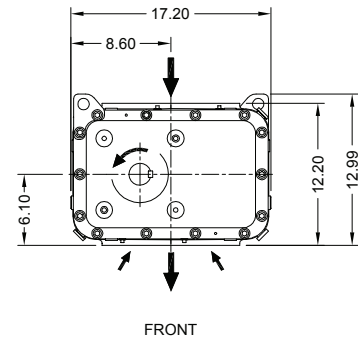
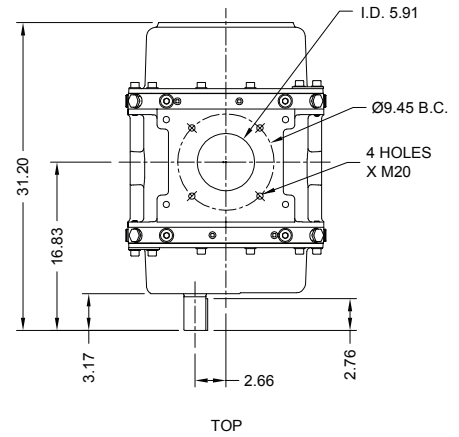

Spare parts and accessories

Kit 1 - STANDARD MAINTENANCE KIT	Kit 2 - SET OF RING HOLDERS	Kit 3 - SET OF GEARS	MANIFOLD AND DISCHARGE/INJECTION MANIFOLD GASKETS	HIBON LUBE
<p>Contains all parts required for 40 000 h. maintenance</p>				

For more information about spares and accessories, contact your nearest Service Center or Ingersoll Rand - HIBON company.

Compressed Air Systems and Services
 Higon Inc
 100 Voyageur Pointe Claire, Quebec
 Canada, H9R 6A8
 Tel: 514 631-3501
 Fax: 877 584 0307
 www.higon.com www.ingersollrand.com

Ingersoll Rand (NYSE:IR) advances the quality of life by creating comfortable, sustainable and efficient environments. Our people and our family of brands—including Club Car®, Ingersoll Rand®, Thermo King® and Trane®—work together to enhance the quality and comfort of air in homes and buildings; transport and protect food and perishables; and increase industrial productivity and efficiency. We are a \$13 billion global business committed to a world of sustainable progress and enduring results.

ingersollrandproducts.com
 We are committed to using environmentally conscious print practices

Ingersoll Rand Air Solutions Higon®
 2 avenue Jean-Paul Sartre, 59290 WASQUEHAL France
 Tel +33 (0) 3 20 45 39 39
 Fax +33 (0) 3 20 45 39 20 (Fax Service)
 www.higon.com www.ingersollrand.com
 email : higon@irco.com

